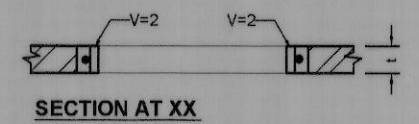

FIG.-6 TYPICAL DETAIL OF PROVIDING VERTICAL STEEL BARS IN BRICK MASONRY

TABLE :6 VERTICAL STEEL REINFORCEMENT IN MASONRY WALLS WITH RECTANGULAR MASONRY UNITS

NO. OF STOREYS	STOREYS	DIAMETER OF HSD SINGLE BAR IN MM AT EACH CRITICAL SECTION			
		CATEGORY B	CATEGORY C	CATEGORY D	CATEGORY E
(1)	(2)	(3)	(4)	(5)	(6)
ONE	NIL	NIL	NIL	# 10	# 12
TWO	TOP BOTTOM	NIL NIL	NIL NIL	# 10 # 12	R.C.C.FRAMED CONSTRUCTION RECOMMENDED

13. VERTICAL REINFORCEMENT AT JAMBS OF WINDOWS AND DOOR OPENING SHALL BE PROVIDED AS PER TABLE - 6 AND FIG. -7. IT SHALL START FROM FOUNDATION OF FLOOR AND TERMINATE IN LINTEL BAND.



w-WINDOW
t=WALL THICKNESS
t1=LINTEL THICKNESS
t2=THICKNESS OF CONCRETE
v=VERTICAL BAR

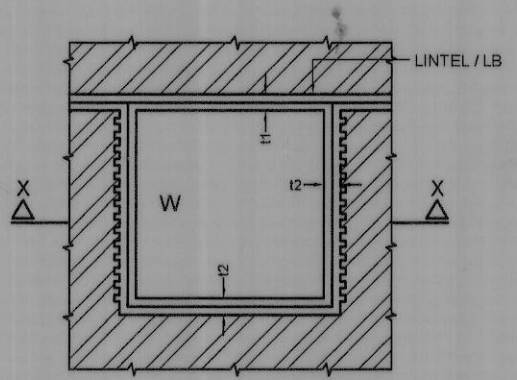

FIG.7 STRENGTHENING MASONRY AROUND OPENING

14. DOWEL BARS SHALL BE USED AT CORNERS AND T- JUNCTIONS OF WALLS AT THE SILL LEVEL OF WINDOWS TO LENGTH OF 900 MM FROM THE INSIDE CORNER IN EACH WALL. DOWEL BARS SHALL BE IN THE FORM OF U STIRRUPS OF # 8 DIA AND SHALL BE LAID IN 1:3 CEMENT SAND MORTAR WITH A MINIMUM COVER OF 10 MM ON ALL SIDES TO MINIMISE CORROSION.

1	24-04-06	CORRECTED UPTO DATE	<i>[Signature]</i>	<i>[Signature]</i>
SNO.	DATE	DESCRIPTION	T.O. INITIAL	DIR (D)
REVISIONS				
DATE	31-03-06	CHIEF ENGINEER JALANDHAR ZONE		
DRN	RENUKA	SEISMIC PROVISIONS		
TCD				
CKD				
SCALE	AS SHOWN			
SHT. SIZE	A3	SEISMIC STRENGTHENING MEASURES IN MASONRY BUILDINGS		
<i>[Signature]</i> (DEVI SINGH) TECH.OFFICER AAD (ARCH)		DRG. NO.	SHEET NO.	
<i>[Signature]</i> (YOGESH K SINGHAL) SE DIRECTOR (DESIGN) FOR CHIEF ENGINEER		DRG NO CEJZ / STD-216/06	4/8	